

360BV Series

2-Way Instrumentation Ball Valve

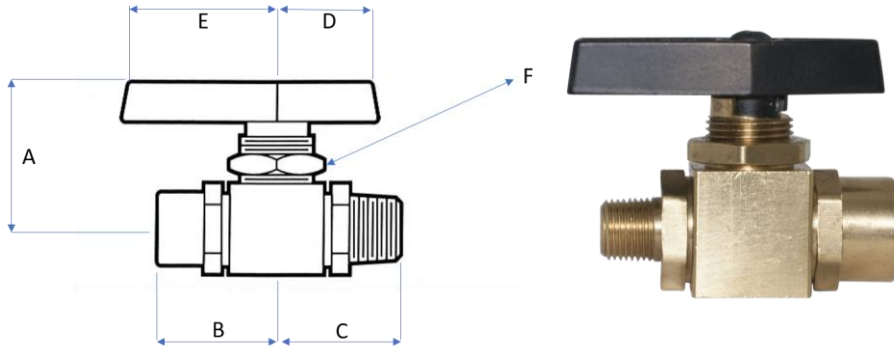

Kantleak™ Instrumentation Ball Valves are designed with double o-ring stem seals to provide over 20,000 leak free cycles. These valves also feature an exclusive stem seal design that never needs tightening and can be panel mounted for instrumentation applications.

- Forged, ASTM B-16 corrosive-resistant brass body
- Quarter-Turn handle design for instantaneous on-off operation
- Blow out proof stem

Pressure Rating:
Up to 1,500 P.S.I.

Part No.	A	B	C	D	E	F
360BV-J	1.25	0.92	0.95	0.85	1.15	0.56
360BV-JxL	1.25	1.00	1.00	0.85	1.15	0.56
360BV-L	1.25	1.00	1.00	0.86	1.15	0.56
360BV-LxN	1.25	1.00	1.00	0.86	1.15	0.56
360BV-N	1.25	1.10	1.07	0.85	1.15	0.56
360BV-P	1.25	1.10	1.07	0.85	1.15	0.56

Part No.	FNPT	MNPT
360BV-J	1/8"	1/8"
360BV-JxL	1/8"	1/4"
360BV-L	1/4"	1/4"
360BV-LxN	1/4"	3/8"
360BV-N	3/8"	3/8"
360BV-P	1/2"	1/2"