

M670 Series

Marine Fuel Shut Off Valve

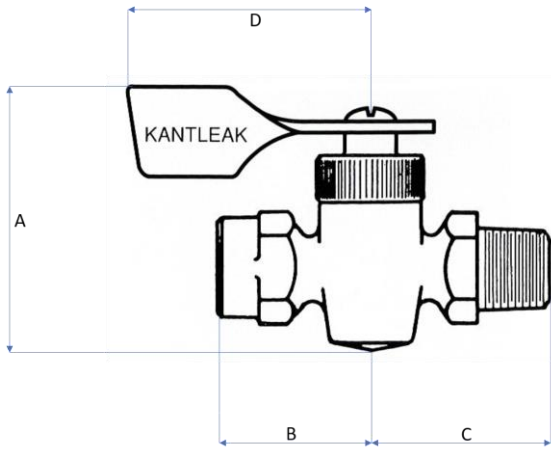

The Kantleak™ Marine Fuel Shut Off Valve is AP approved for use on motor craft fuel lines and is standard with pointer lever and an internal 90° turn stop mechanism to assure positive location of the on and off position. Corrosion proof internal construction assures maximum salt atmosphere protection.

- Port Hole ¼" diameter

Pressure Rating:

Temperature Rating:

Part No.	A	B	C	D
M670C-J	1.88	0.94	1.06	1.63
M670C-L	1.97	1.06	1.19	1.61
M670C-N	1.88	1.12	1.28	1.62

Part No.	FNPT	MNPT
M670C-J	1/8"	X
M670C-L	1/4"	X
M670C-N	3/8"	X