

# M675 Series

## Marine Fuel Shut Off Valve

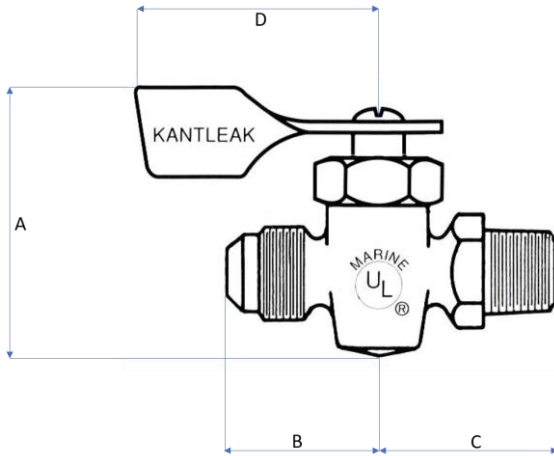

The Kantleak™ Marine Fuel Shut Off Valve is AP approved for use on motor craft fuel lines and is standard with pointer lever and an internal 90° turn stop mechanism to assure positive location of the on and off position. Corrosion proof internal construction assures maximum salt atmosphere protection.

- Port Hole ¼" diameter

Pressure Rating:

Temperature Rating:

Part No.	A	B	C	D
M675C-4J				
M675C-4L	1.88	1.02	1.06	1.63
M675C-5J				
M675C-5L				
M675C-6L	1.88	1.03	1.16	1.63
M675C-6N	1.95	1.06	1.28	1.60

Part No.	O.D. Tube	MNPT
M675C-4J	1/4"	X 1/8"
M675C-4L	1/4"	X 1/4"
M675C-5J	5/16"	X 1/8"
M675C-5L	5/16"	X 1/4"
M675C-6L	3/8"	X 1/4"
M675C-6N	3/8"	X 3/8"